

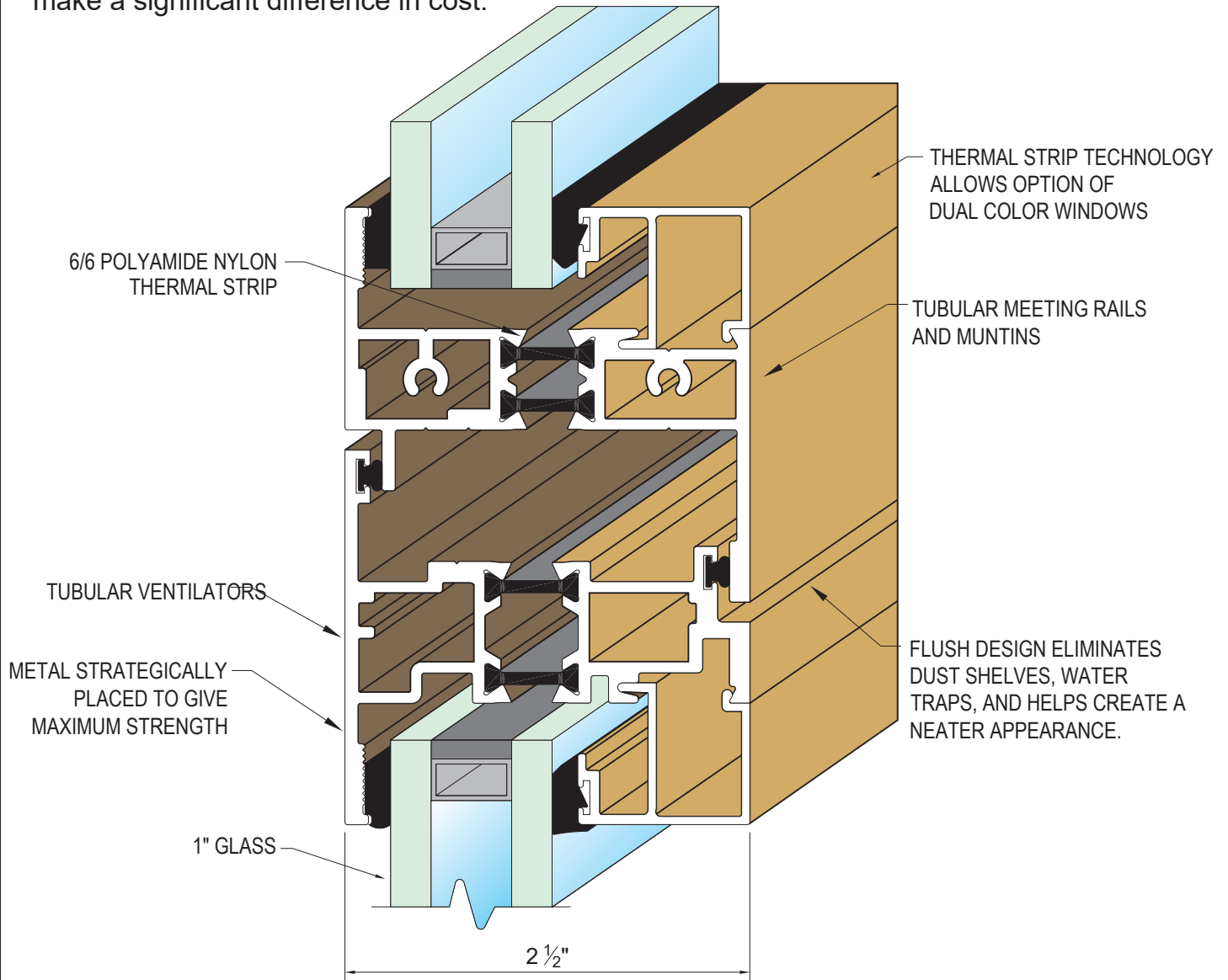

The 4200 series is a lighter weight thermally broken window utilizing Thermal Strip technology©. This series has been designed with metal strategically placed so that it is heavy enough to meet or exceed all HC performance specifications, yet light enough to make a significant difference in cost.



SCALE = FULL SIZE

Features:

- Full 2 1/2" deep frame with double tubular sash, muntins and intermediate rails. *(Consult factory for full specifications)*
- Thermal Strip technology for added strength and Dual Color finishing capability. **(Interior / Exterior)**
- All corners are fastened on each side of the thermal break. Sash corners are mitered, heavy angle reinforced and hydraulically crimped and epoxy welded.
- Flush design eliminates dust shelves and water traps and helps create a clean, neat appearance.
- Each ventilator has two wear resistant nylon glides independent of the hinge to insure maximum alignment and weather tightness.
- The 4200 Series is interchangeable with and lines up with the 4240 Series.

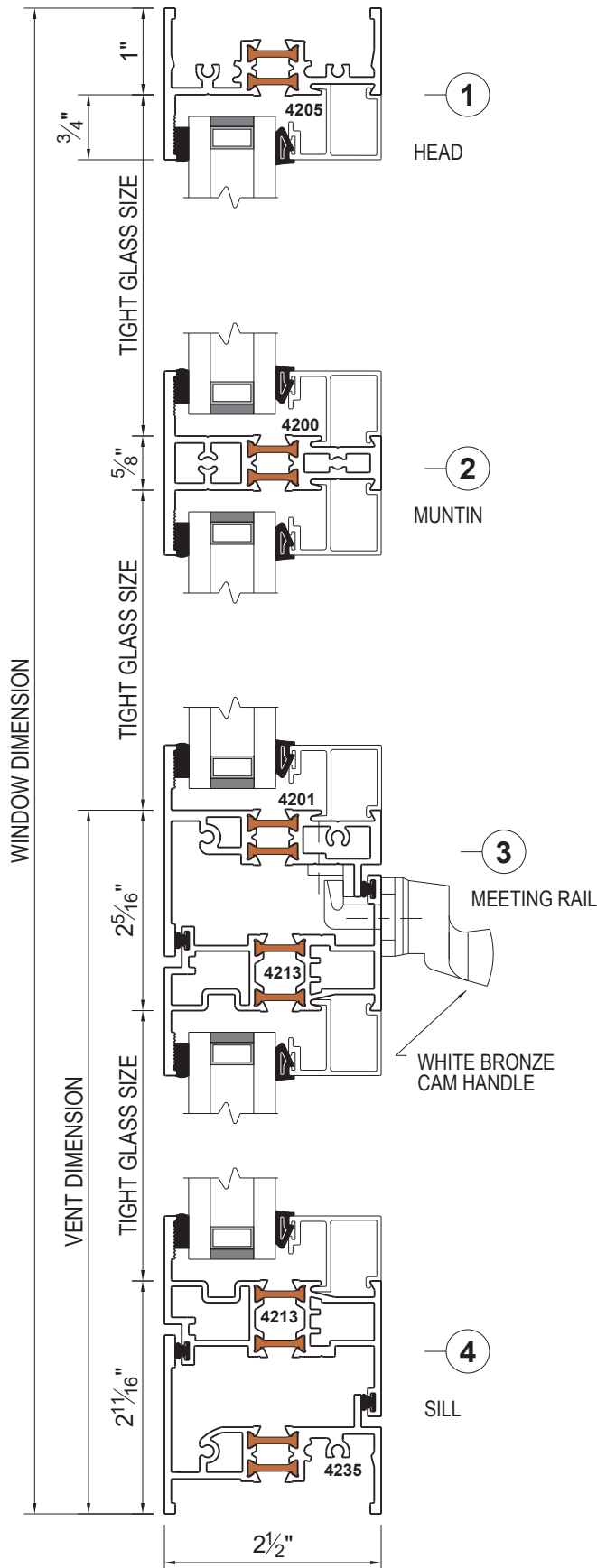

FIXED OVER PROJECT-IN

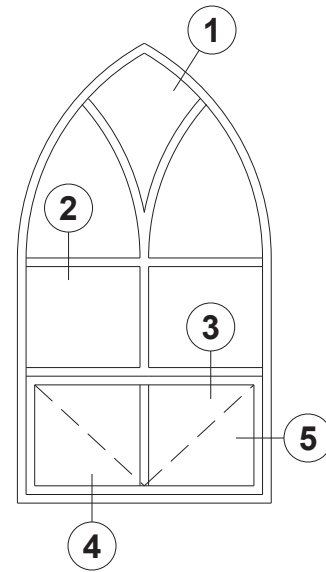

Typical Elevation

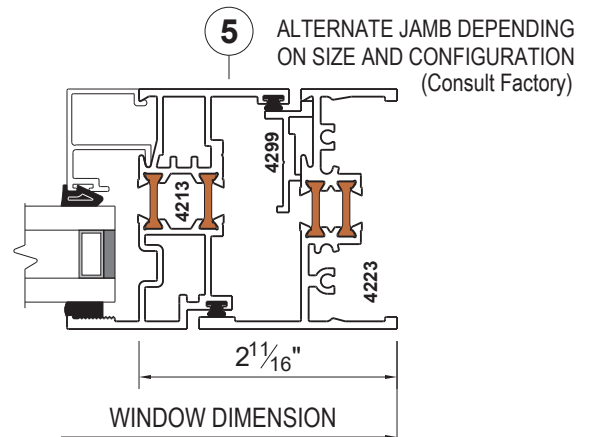
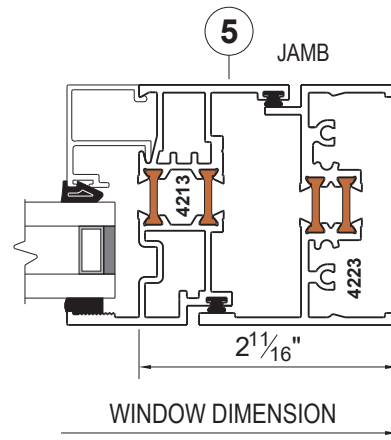

SCALE = HALF SIZE



FIXED OVER PROJECT-OUT

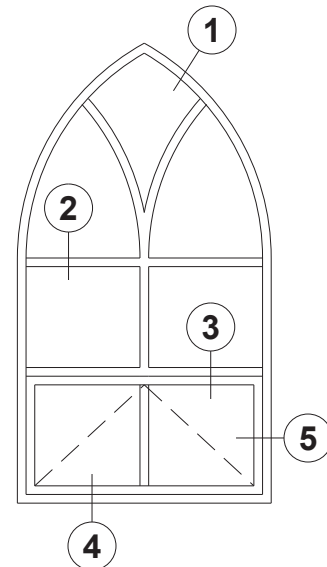
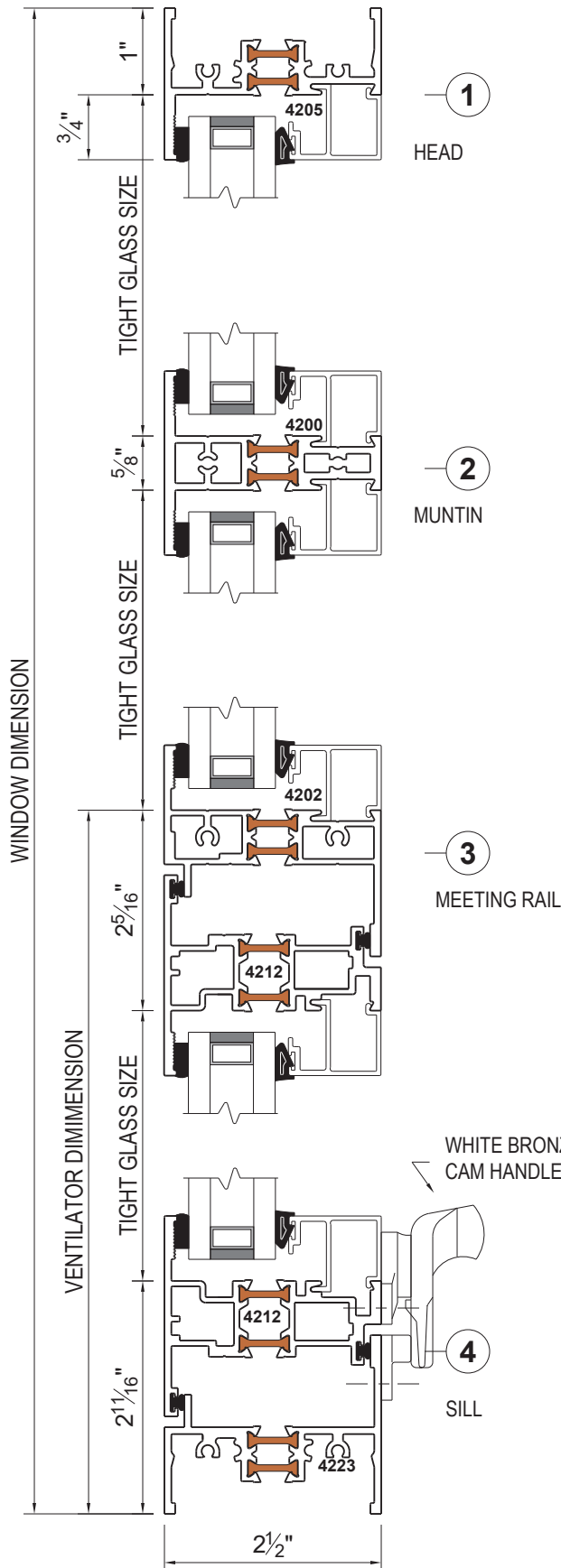

Typical Elevation

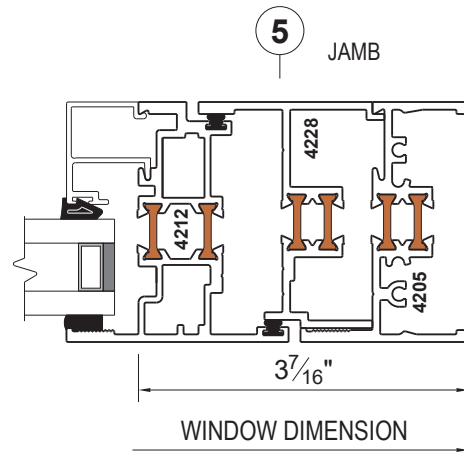

5 ALTERNATE JAMB DEPENDING ON SIZE AND CONFIGURATION (Consult Factory)

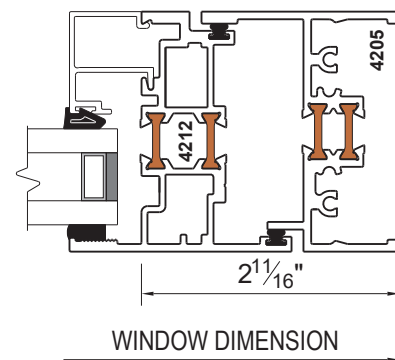

SCALE = HALF SIZE



Since 1906

America's finest custom windows

Alternate project-in ventilator sections that can be used at head, sill or jamb.

PROJECT-IN

(Inswing casement similar)

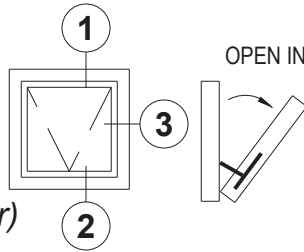

Standard Ventilator
(equal leg frame)

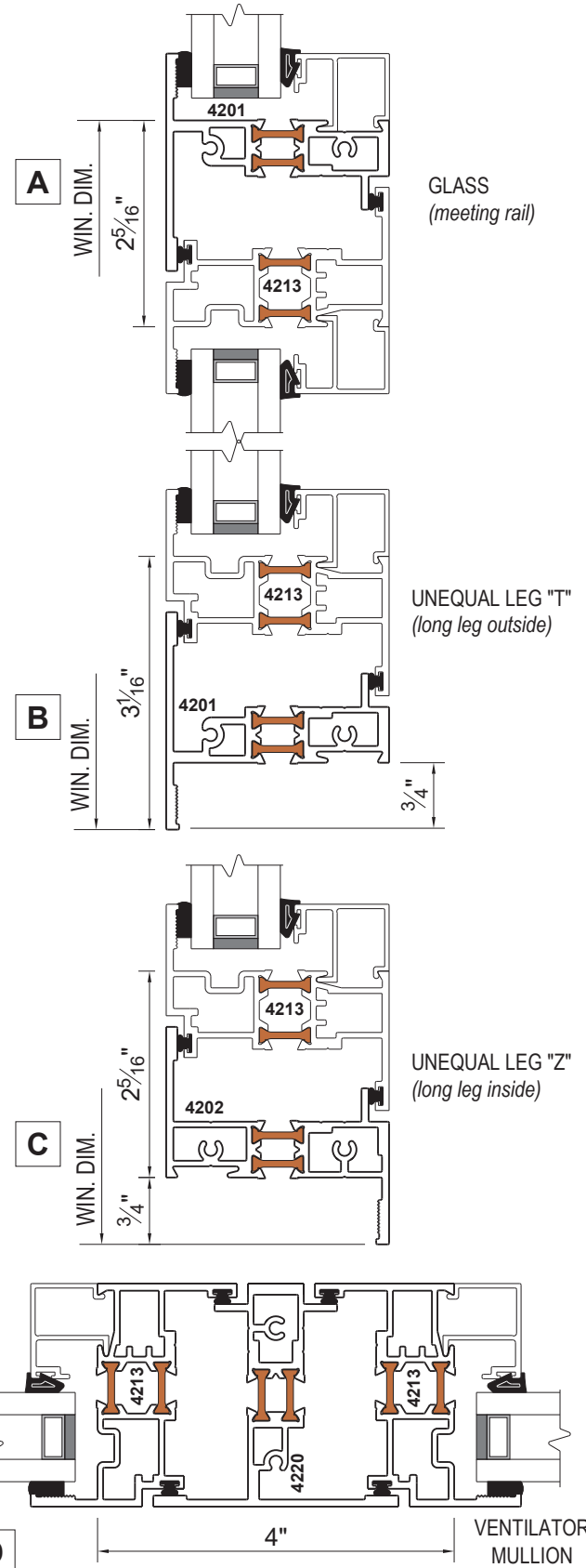
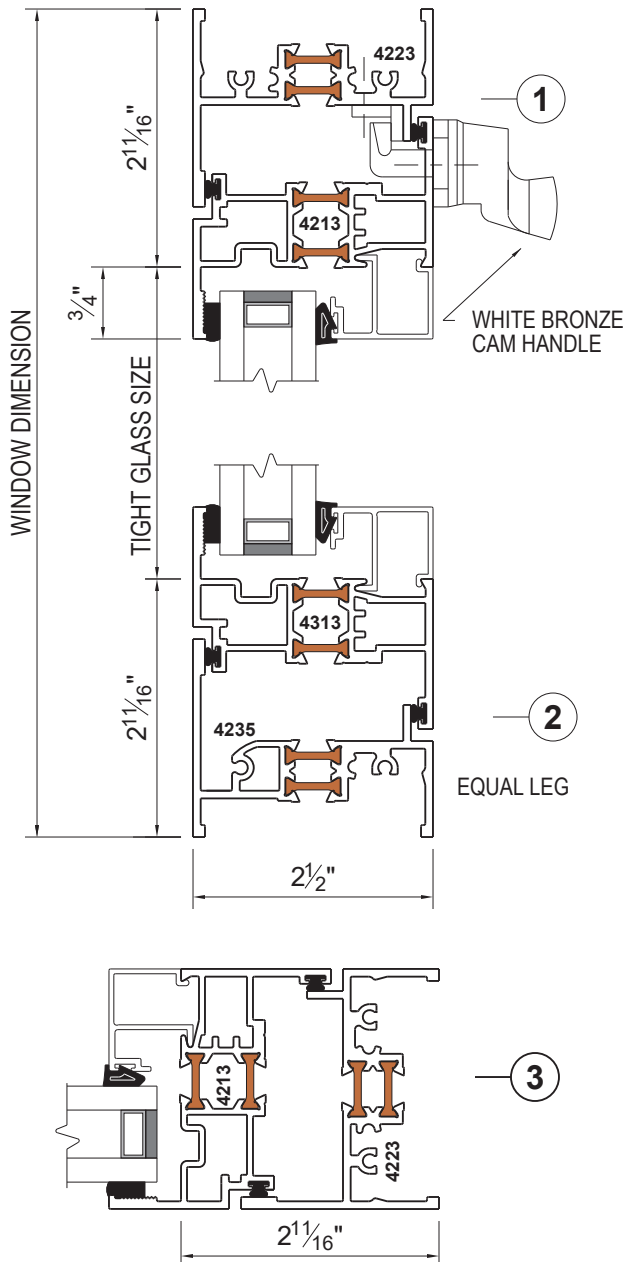

SCALE = HALF SIZE



Since 1906

America's finest custom windows

Alternate project-out ventilator sections that can be used at head, sill or jamb.

PROJECT-OUT

(Outswing casement similar)

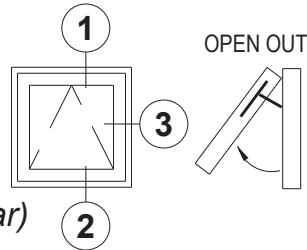

Standard Ventilator
(equal leg frame)

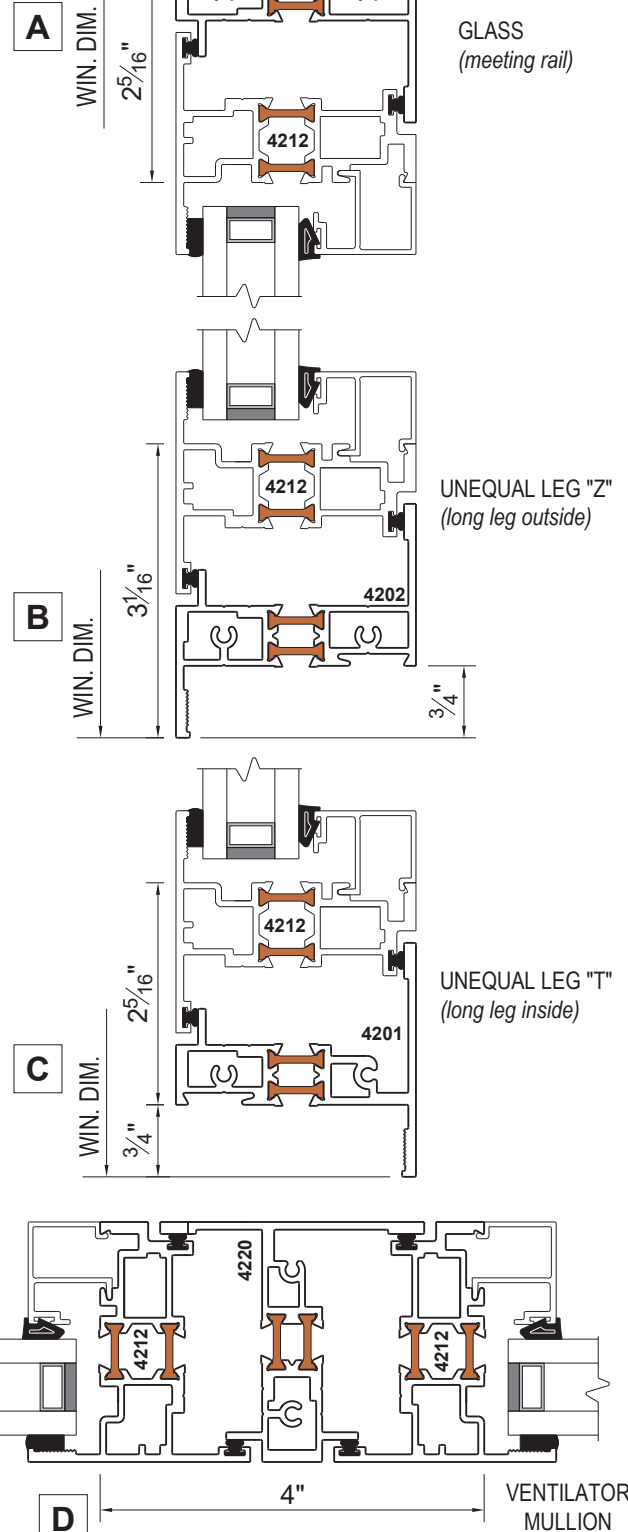
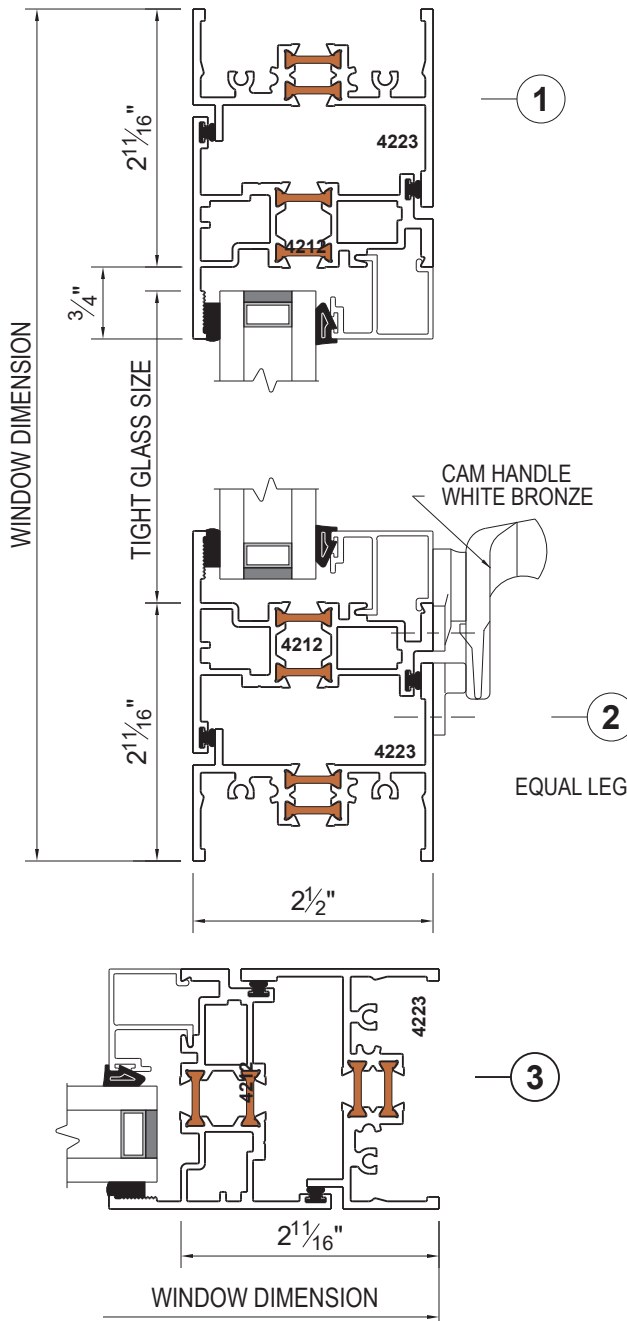

SCALE = HALF SIZE



Since 1906

America's finest custom windows

OUTSWING CASEMENT

Hardware not shown. Push-pull operation with cam handles and stainless steel concealed 4 bar hinges are standard. Crank operation with rotos and 5 knuckle extruded aluminum butt hinges are optional.

(equal leg frame)

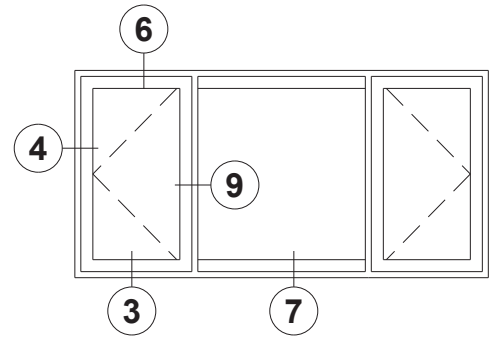
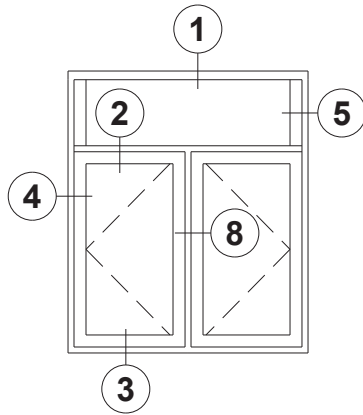
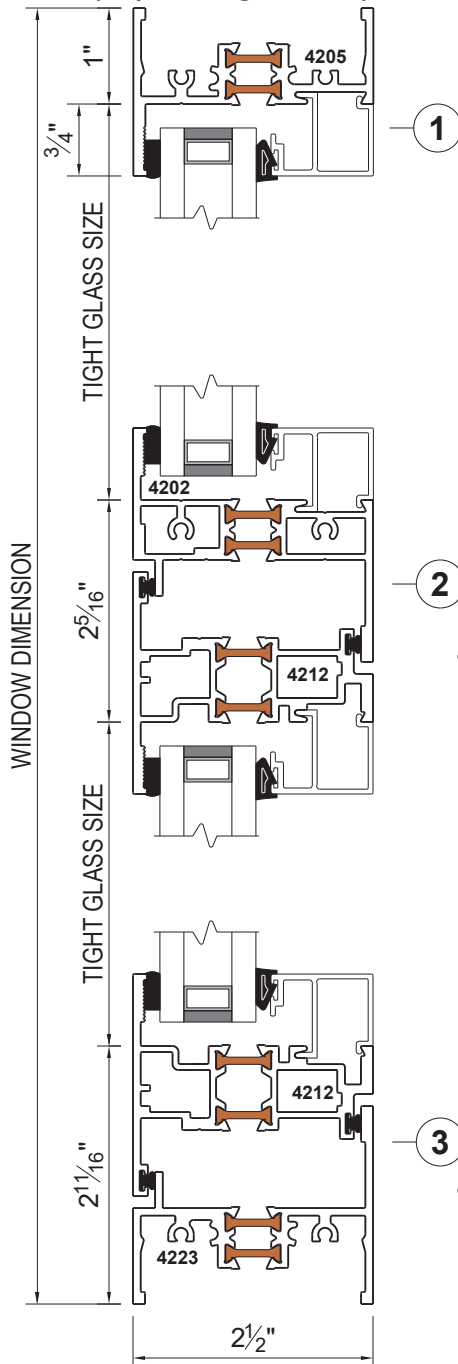

Typical Elevations

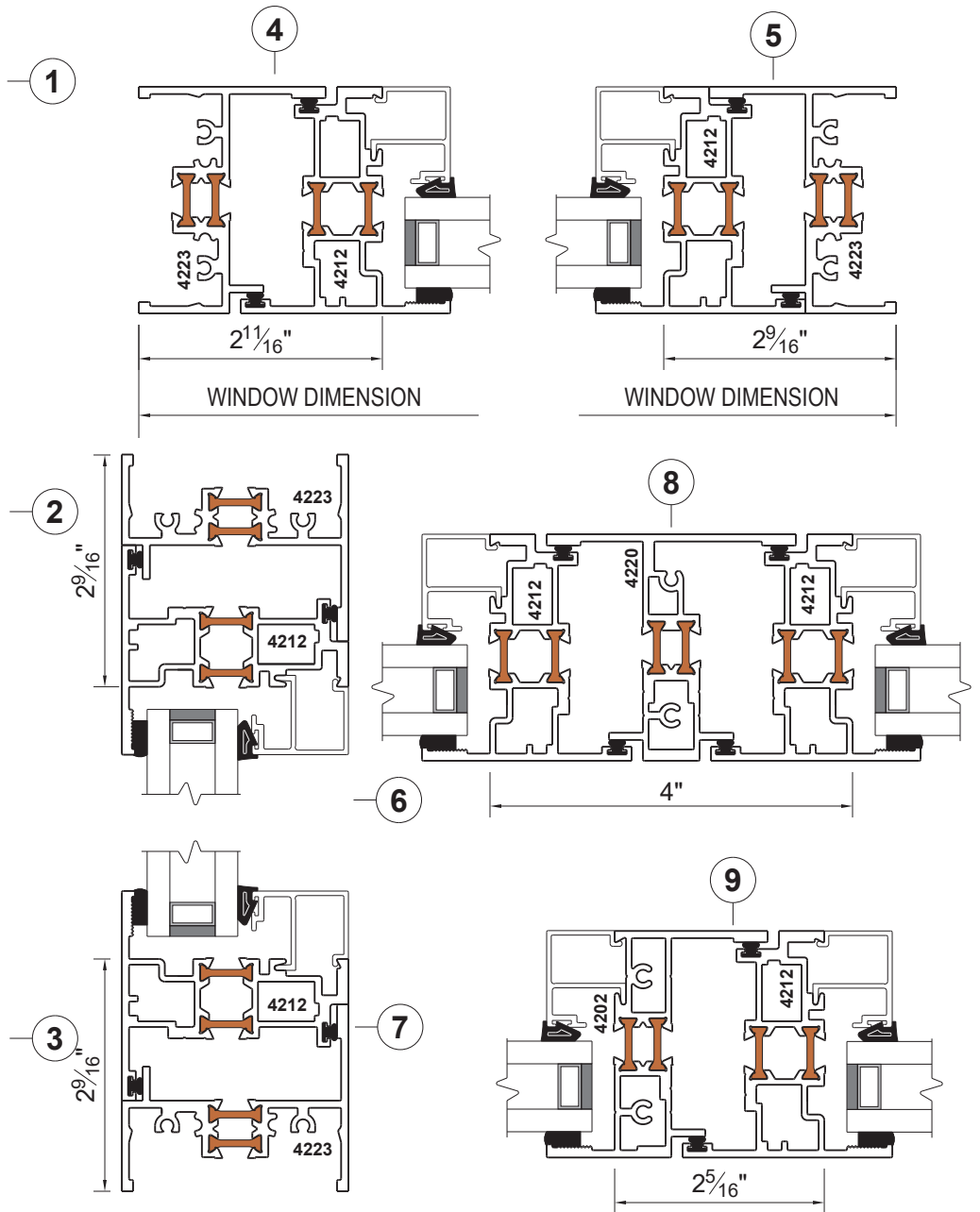

SCALE = HALF SIZE



Since 1906

America's finest custom windows

IN SWING CASEMENT

Hardware not shown. Push-pull operation with cam handles and stainless steel 4 bar hinges are standard. 5 knuckle extruded aluminum butt hinges are optional.

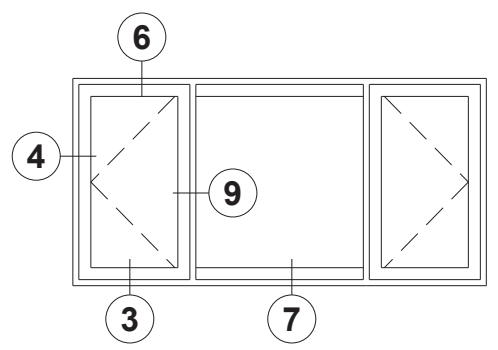
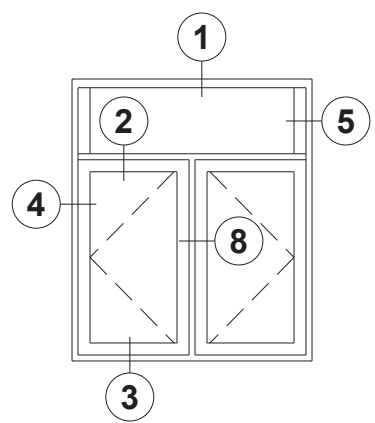

Typical Elevations

(equal leg frame)

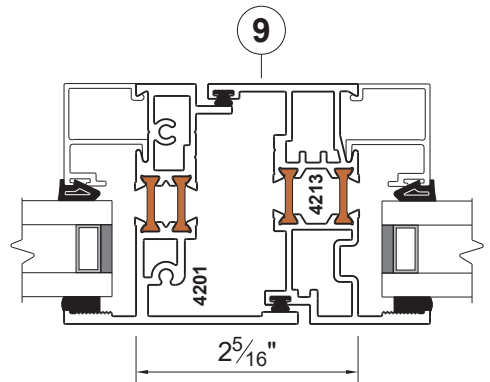
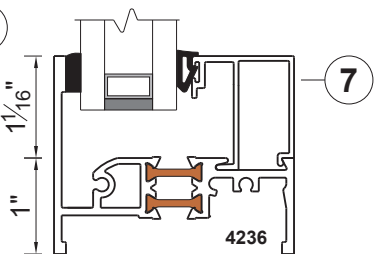
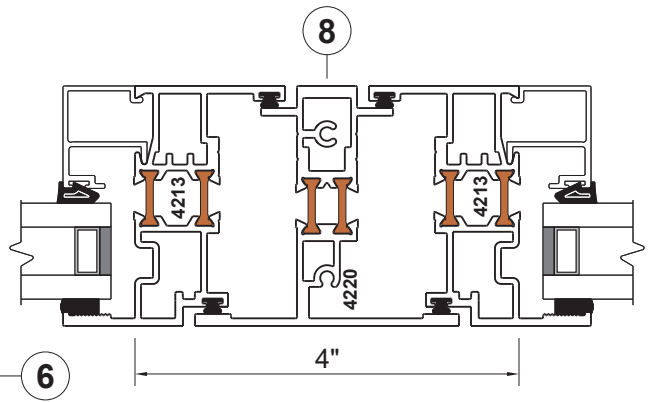
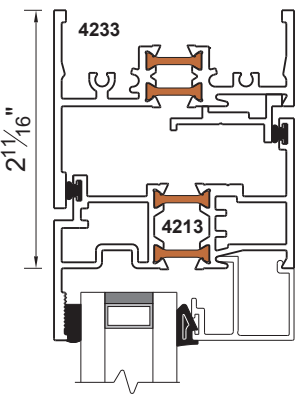
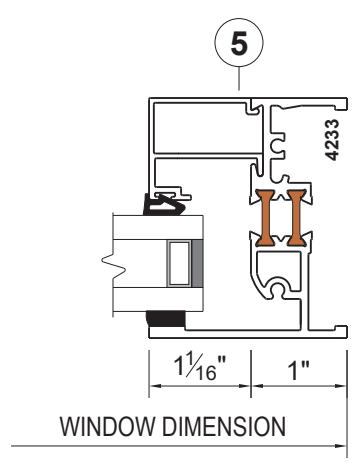
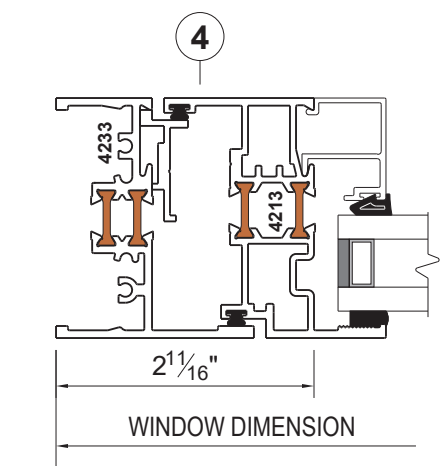
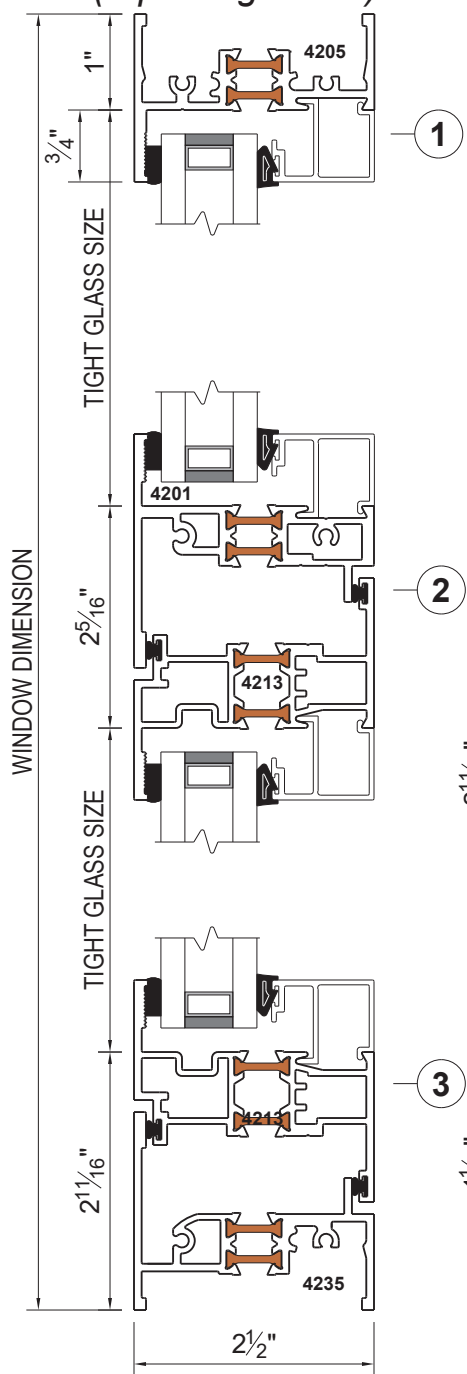

SCALE = HALF SIZE



Since 1906

America's finest custom windows

Fixed Perimeter Frame Sections

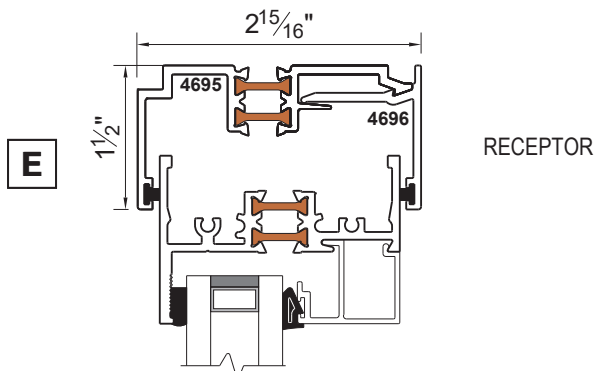
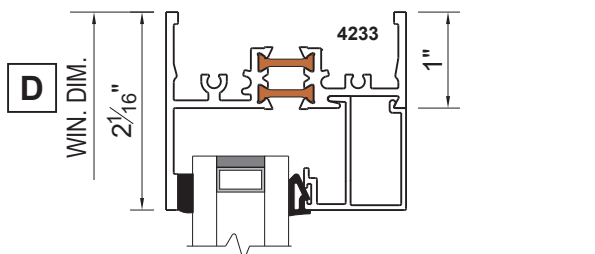
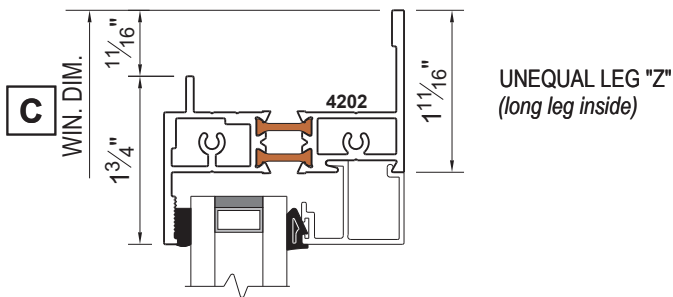
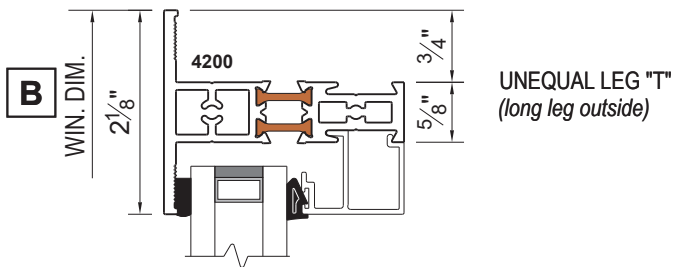
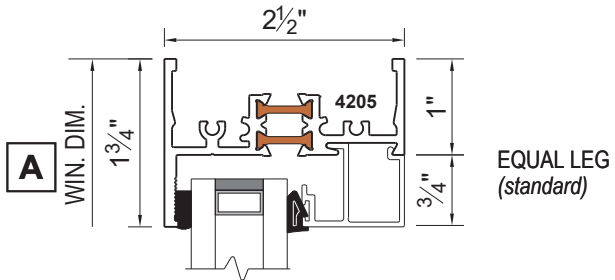

Muntin

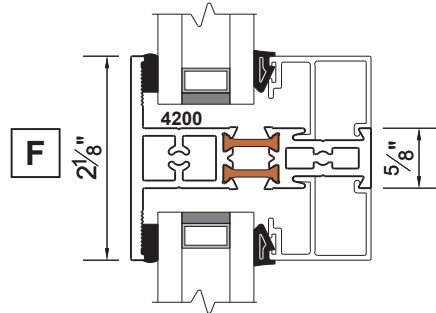

Vertical and Horizontal Stacking

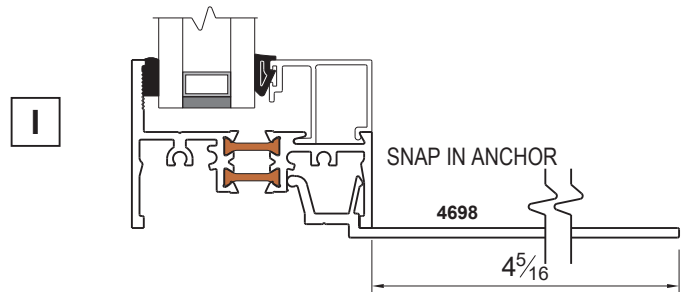
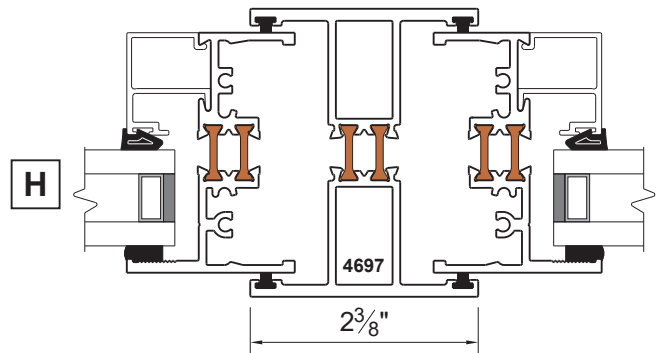
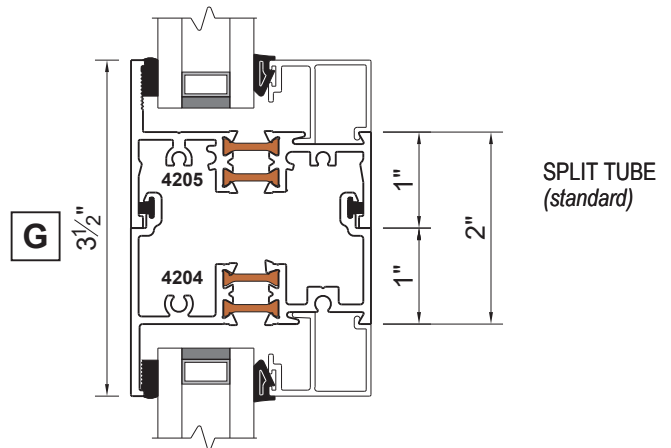

SCALE = HALF SIZE

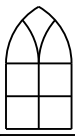

The 4240 Series is 4" deep and is used for large windows or for design variation. The 4240 Series lines up with, and is interchangeable with the 4200 Series. 4200 Series ventilators can easily be incorporated into the 4220 Series. All sections can be used horizontally or vertically.

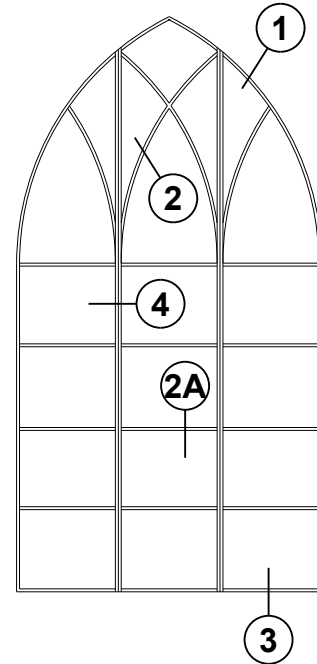
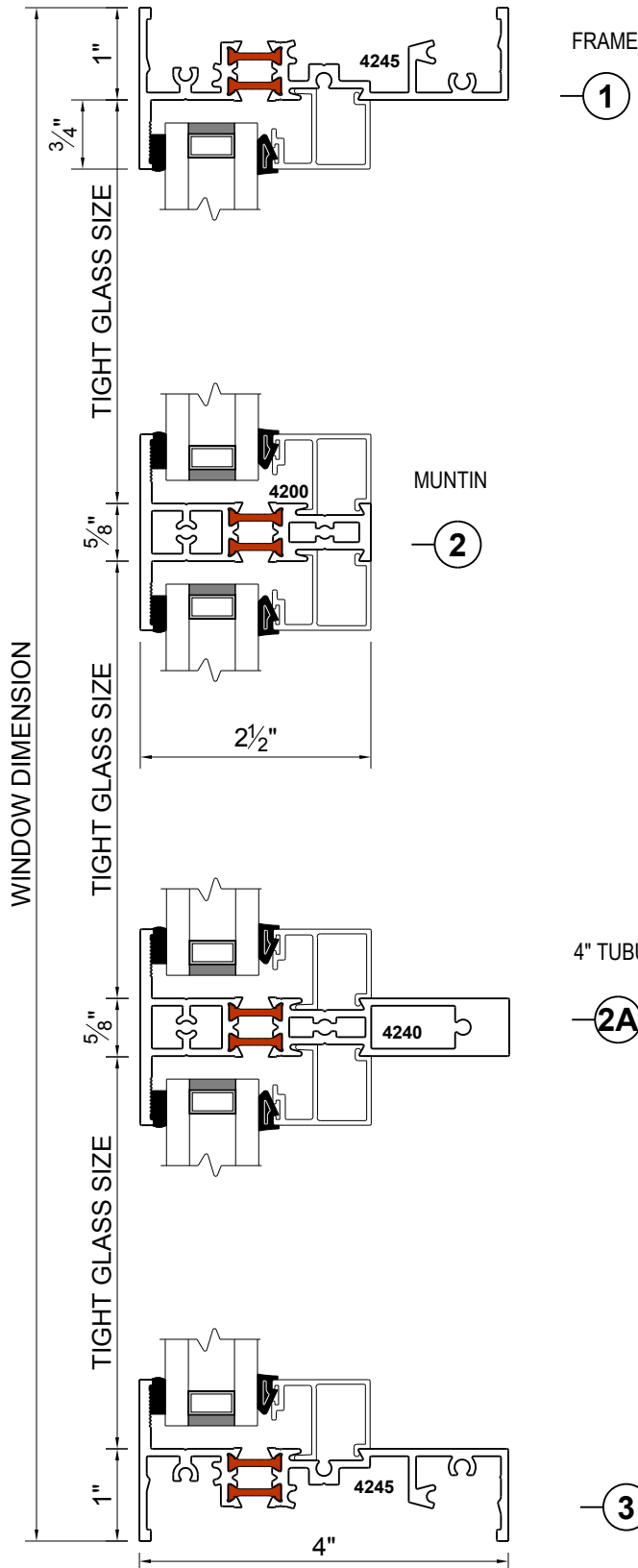

Typical Elevation

4" TUBULAR MUNTIN

2A Alternate

4 SPLIT TUBE/
STACKING MULLION

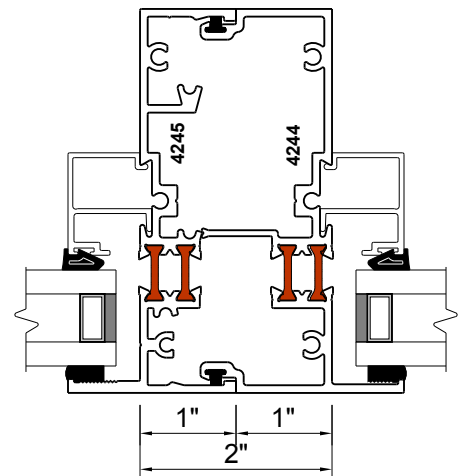

SCALE = HALF SIZE